

CDMA Mobile Communication & IS-95

Outline



- Spread Spectrum Basics
- Spreading Codes
- IS-95 Features- Transmitter/Receiver
- Power Control
- Diversity Techniques
- RAKE Receiver
- Soft Handoff

Spread Spectrum

- A technique in which the transmission bandwidth W and message bandwidth R are related as

$$W \gg R$$

- Counter intuitive
- Achieves several desirable objectives for e.g. enhanced capacity

Application of Spread Spectrum Systems

- Antijamming
- Multiple access
- Low detectability
- Message Privacy
- Selective calling
- Identification
- Navigation
- Multipath protection
- Low radiated flux density

Types of Spread Spectrum Systems

- Frequency Hopping
- Direct Sequence
- Frequency Hopping
 - Slow Frequency Hopping - multiple symbols per hop
 - Fast Frequency Hopping - multiple hops per symbol
- Care is taken to avoid or minimize collisions of hops from different users

Frequency Hopping

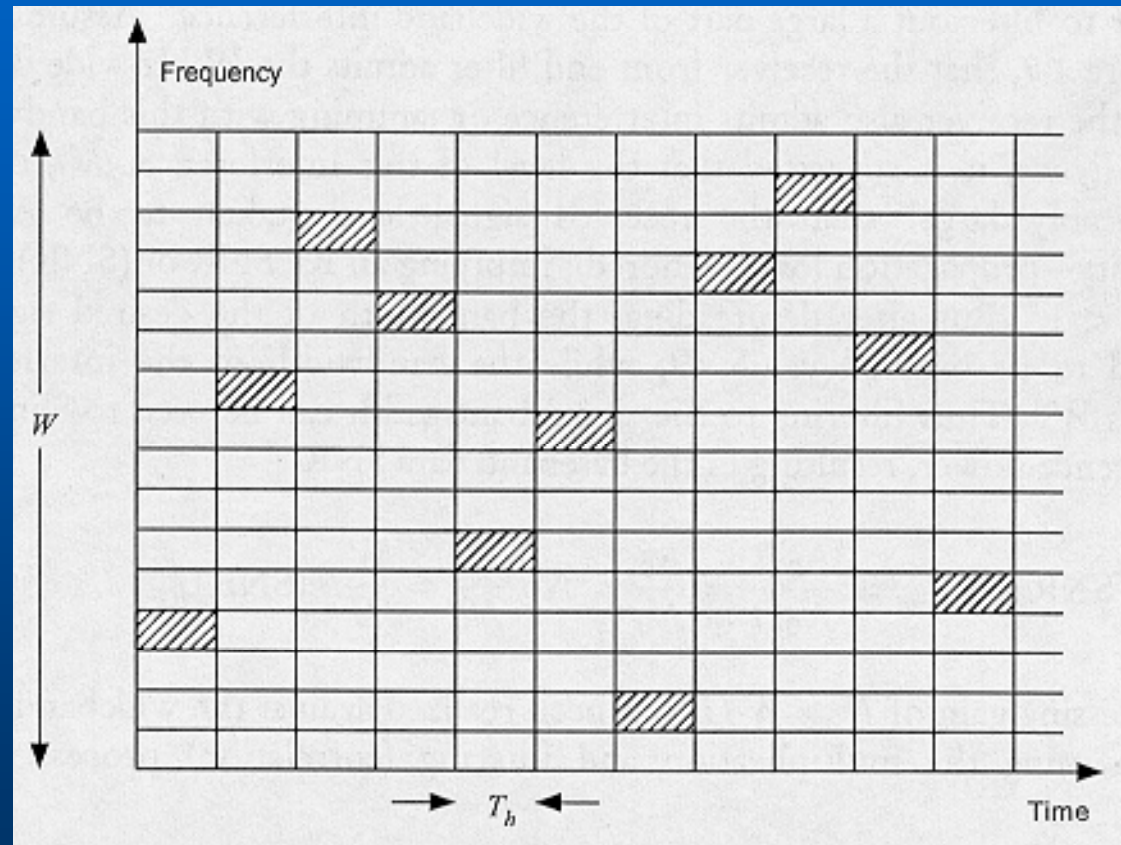

Typical frequency-hopping waveform pattern

Direct Sequence

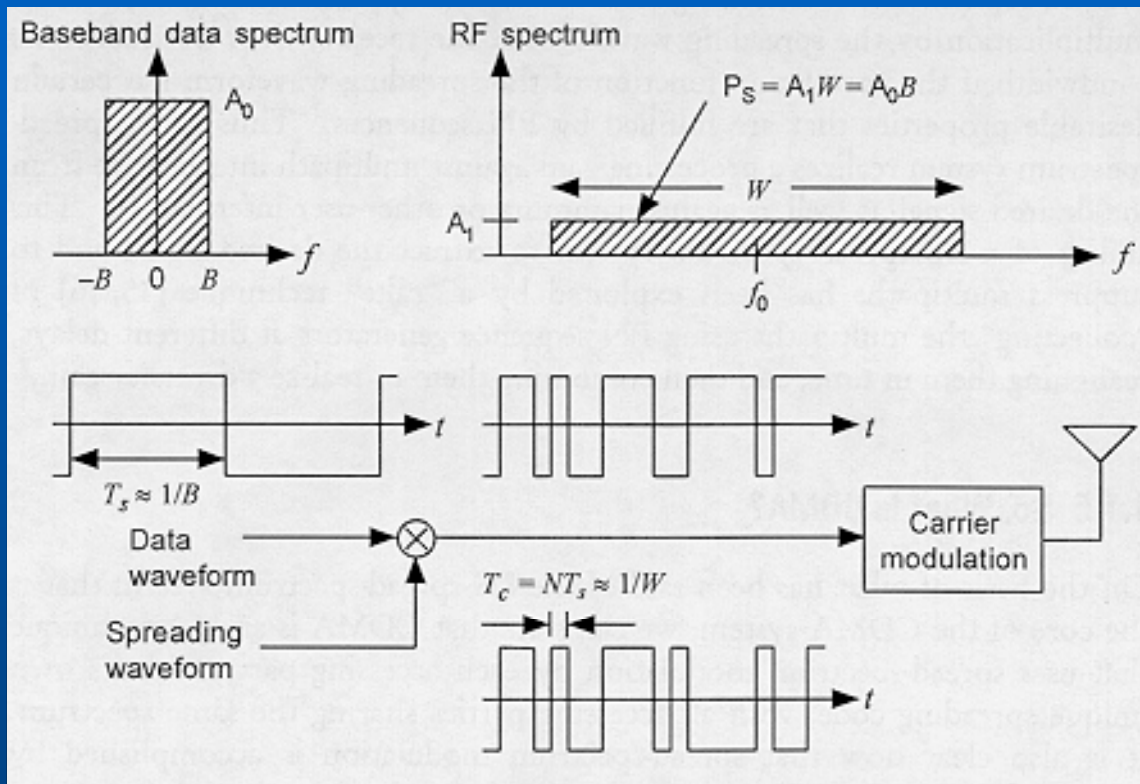

Transmitter side of system

Direct Sequence (contd...)

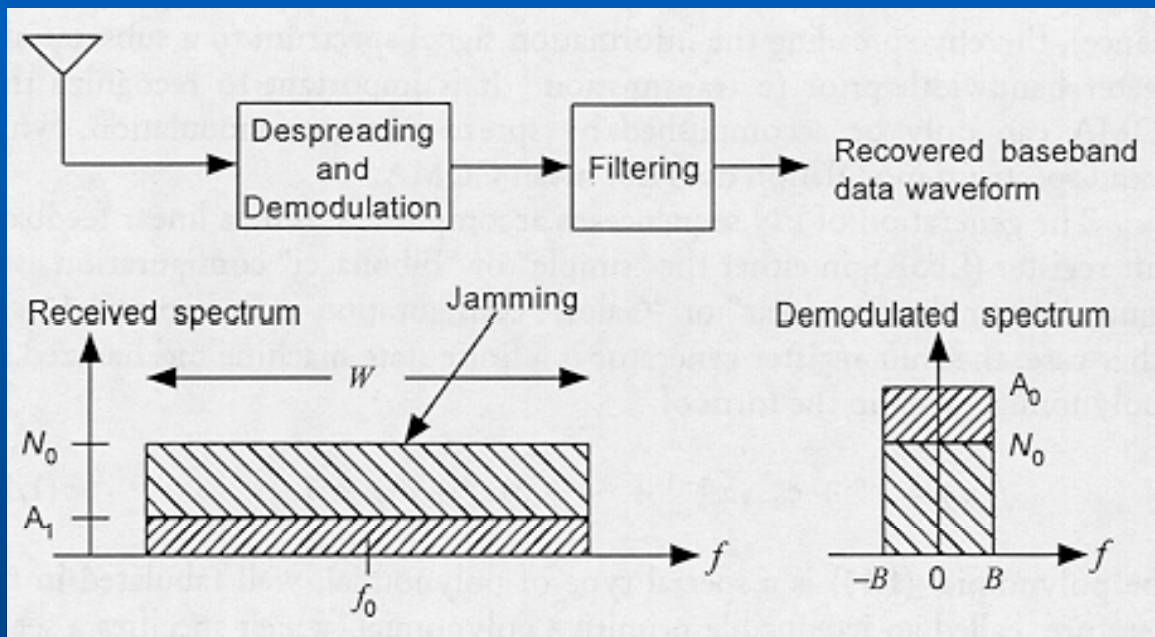

Receiver side of system

Code Division Multiple Access - CDMA

- Multiple users occupying the same band by having different codes is known as a CDMA - Code Division Multiple Access system

Let

W - spread bandwidth in Hz

$R = 1/T_b =$ Data Rate (data signal bandwidth in Hz)

S - received power of the desired signal in W

J - received power for undesired signals like multiple access users, multipath, jammers etc in W

E_b - received energy per bit for the desired signal in W

N_0 - equivalent noise spectral density in W/Hz

CDMA (contd...)

$$\frac{J}{S} = \frac{N_0 W}{E_b / T_b} = \frac{W T_b}{E_b / N_0} = \frac{W / R}{E_b / N_0}$$

$$\left(\frac{J}{S} \right)_{\max} = \frac{W / R}{(E_b / N_0)_{\min}}$$

What is the tolerable interference over desired signal power?

$$\left(\frac{J}{S} \right)_{\max} = \text{Jamming margin (db)} = \frac{W}{R} \text{ (db)} - \left(\frac{E_b}{N_0} \right)_{\min} \text{ (db)}$$

CDMA (contd...)

- In conventional systems $W/R \approx 1$ which means, for satisfactory operation $J/S < 1$
- Example Let $R = 9600$; $W = 1.2288$ MHz
 $(E_b/N_0)_{\min} = 6$ dB (values taken from IS-95)
Jamming margin (JM) = $10\log_{10}(1.2288 \cdot 10^6 / 9.6 \cdot 10^3) - 6$
 $= 15.1$ dB $\equiv 32$
- This antijam margin or JM arises from Processing Gain (PG) = $W/R = 128$
- If $(E_b/N_0)_{\min}$ is further decreased or PG is increased, JM can be further increased

CDMA (contd...)

- JM is a necessary but not a sufficient condition for a spread spectrum system. For eg. FM is not a spread spectrum system
- JM can be used to accommodate multiple users in the same band
- If $(E_b/N_0)_{\min}$ and PG is fixed, number of users is maximized if perfect power control is employed.
- Capacity of a CDMA system is proportional to PG.

Universal Frequency Reuse

- Objective of a Wireless Communication System
 - Deliver desired signal to a designated receiver
 - Minimize the interference that it receives
- One way is to use disjoint slots in frequency or time in the same cell as well as adjacent cells - Limited frequency reuse
- In spread spectrum, universal frequency reuse applies not only to users in the same cell but also in all other cells
- No frequency plan revision as more cells are added

Universal Frequency Reuse (contd...)

- As traffic grows and cells sizes decrease, transmitted power levels in both directions can be reduced significantly
- Resource allocation of each user's channel is energy (instead of time and frequency)
- Hence interference control and channel allocations merge into a single approach

Spreading Codes

- It is desired that each user's transmitted signal appears noise like and random. Strictly speaking, the signals should appear as Gaussian noise
- Such signals must be constructed from a finite number of randomly preselected stored parameters; to be realizable
- The same signal must be generated at the receiver in perfect synchronization
- We limit complexity by specifying only one bit per sample i.e. a binary sequence

Desirable Randomness Properties

- Relative frequencies of “0” and “1” should be $\frac{1}{2}$ (Balance property)
- Run lengths of zeros and ones should be (Run property):
 - Half of all run lengths should be unity
 - One - quarter should be of length two
 - One - eighth should be of length three
 - A fraction $\frac{1}{2^n}$ of all run lengths should be of length n for all finite n

Desirable Randomness Properties (contd...)



- If the random sequence is shifted by any nonzero number of elements, the resulting sequence should have an equal number of agreements and disagreements with the original sequence (Autocorrelation property)

PN Sequences

- A deterministically generated sequence that nearly satisfies these properties is referred to as a Pseudorandom Sequence (PN)
- Periodic binary sequences can be conveniently generated using linear feedback shift registers (LFSR)
- If the number of stages in the LFSR is r , $P \leq 2^r - 1$ where P is the period of the sequence

PN Sequences (contd...)

- However, if the feedback connections satisfy a specific property, $P = 2^r - 1$. Then the sequence is called a Maximal Length Shift Register (MLSR) or a PN sequence.
- Thus if $r=15$, $P=32767$.

Randomness Properties of PN Sequences

- *Balance property* - Of the $2^r - 1$ terms, 2^{r-1} are one and $2^{r-1} - 1$ are zero. Thus the unbalance is $1/P$. For $r=50$; $1/P \cong 10^{-15}$
- *Run property* - Relative frequency of run length n (zero or ones) is $1/2^n$ for $n \leq r-1$ and $1/(2^r - 1)$ for $n = r$
- One run length each of $r-1$ zeros and r ones occurs. There are no run lengths for $n > r$
- *Autocorrelation property* - The number of disagreements exceeds the number of agreements by unity. Thus again the discrepancy is $1/p$

Randomness Properties of PN Sequences (contd.)

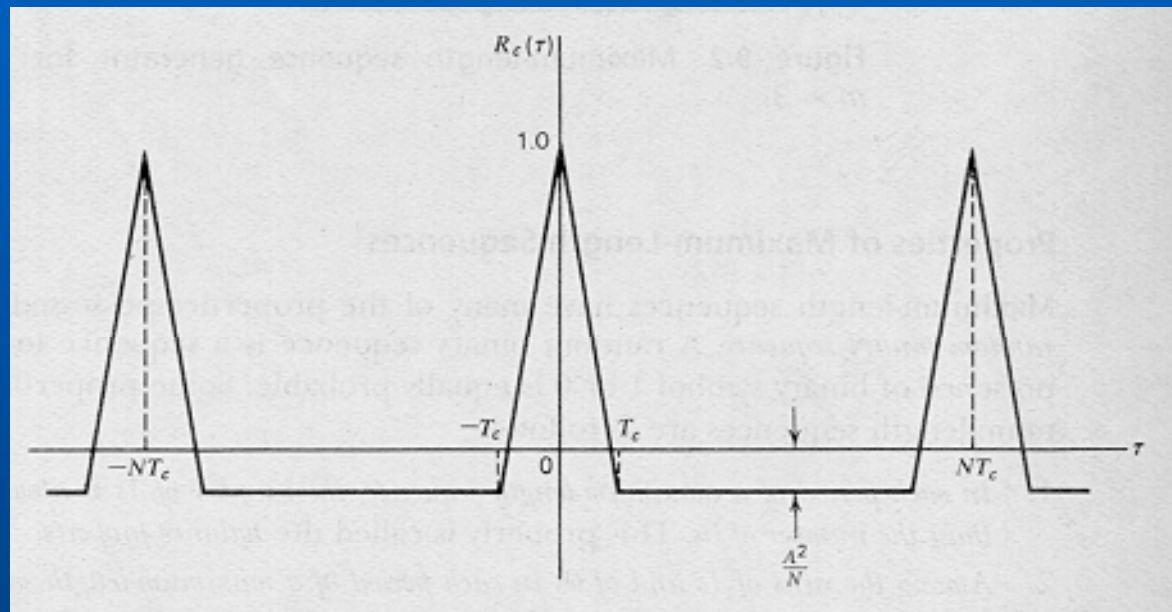

Autocorrelation function

Randomness Properties of PN Sequences (contd...)

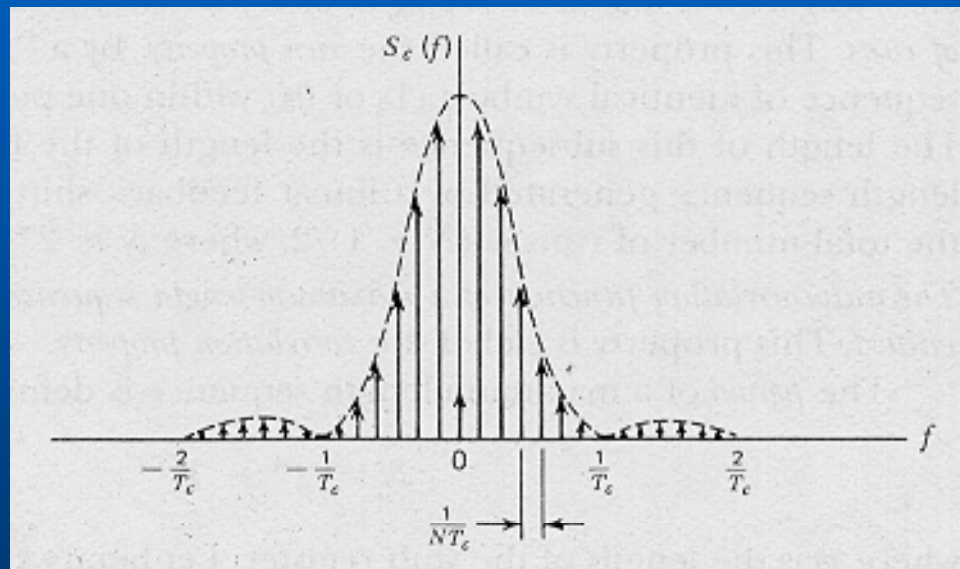

Power Spectral Density

SR Implementation of PN Sequences

- The feedback connection should correspond to a primitive polynomial.
- Primitive polynomials of every degree exist. The number of primitive polynomials of degree r is given by :

$$N = \frac{2^r - 1}{r} \prod_{i=1}^J \frac{P_i - 1}{P_i} \quad \text{where } 2^r - 1 = \prod_{i=1}^J P_i^{e_i}$$

- Simple Shift Register Generator (SSRG) - Fibonacci configuration.
- Modular Shift Register Generator (MSRG) - Galois configuration.

SR Implementation of PN Sequences

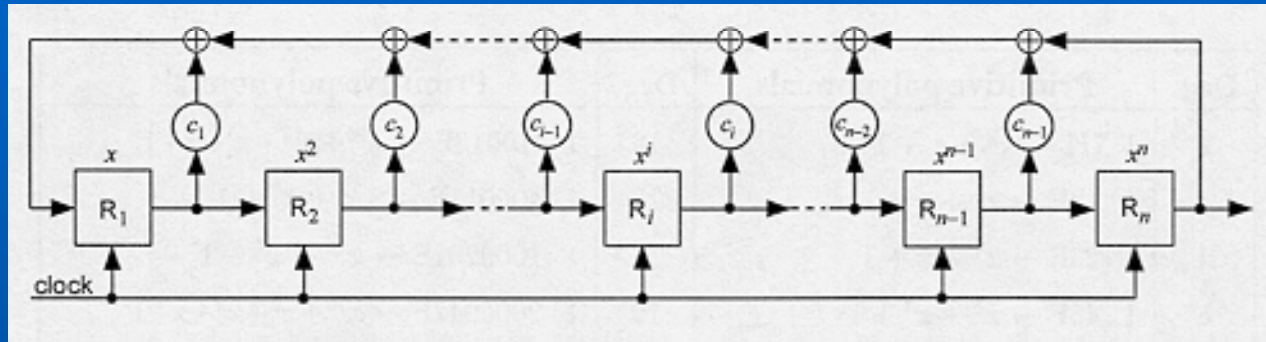

SSRG configuration of $f(x) = 1 + c_1x + c_2x^2 + \dots + c_ix^i + \dots + c_{n-1}x^{n-1} + x^n$

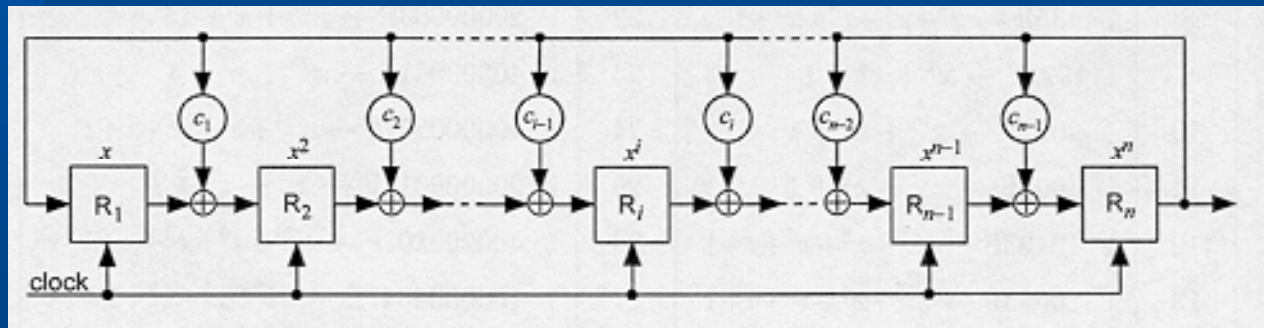

MSRG configuration of $f(x) = 1 + c_1x + c_2x^2 + \dots + c_ix^i + \dots + c_{n-1}x^{n-1} + x^n$

PN Sequences Specified in IS-95

- A “long” PN sequence ($r = 42$) is used to scramble the user data with a different code shift for each user
- The 42-degree characteristic polynomial is given by:
 - $x^{42} + x^{41} + x^{40} + x^{39} + x^{37} + x^{36} + x^{35} + x^{32} + x^{26} + x^{25} + x^{24} + x^{23} + x^{21} + x^{20} + x^{17} + x^{16} + x^{15} + x^{11} + x^9 + x^7 + 1$
- The period of the long code is $2^{42} - 1 \approx 4.4 \cdot 10^2$ chips and lasts over 41 days

PN Sequences Specified in IS-95 (contd...)

- Two “short” PN sequences ($r=15$) are used to spread the quadrature components of the forward and reverse link waveforms
- The characteristic polynomials are given by :
 - $x^{15}+x^{10}+x^8+x^7+x^6+x^2+x$ (I-channel)
 - $x^{15}+x^{12}+x^{11}+x^{10}+x^9+x^5+x^4+x^3+1$ (Q-channel)
- The period of the short code is:
 $2^{15} - 1 = 32767$ chips $\equiv 80/3$ ms

Orthogonal Spreading Codes – Walsh Codes

Walsh functions of order N are defined as a set of N time functions denoted as $\{W_j(t); t \in (0, T), j=0, 1, \dots, N-1\}$ such that:

- $W_j(t)$ takes on the values $\{+1, -1\}$ except at the jumps, where it takes the value zero
- $W_j(t) = 1$ for all j
- $W_j(t)$ has precisely j sign changes in the interval $(0, T)$

$$\int_0^T W_j(t)W_k(t)dt = \begin{cases} 0 & \text{if } j \neq k \\ T & \text{if } j = k \end{cases}$$

- Each $W_j(t)$ is either even or odd with respect to $T/2$ i.e. the mid point

Walsh Functions

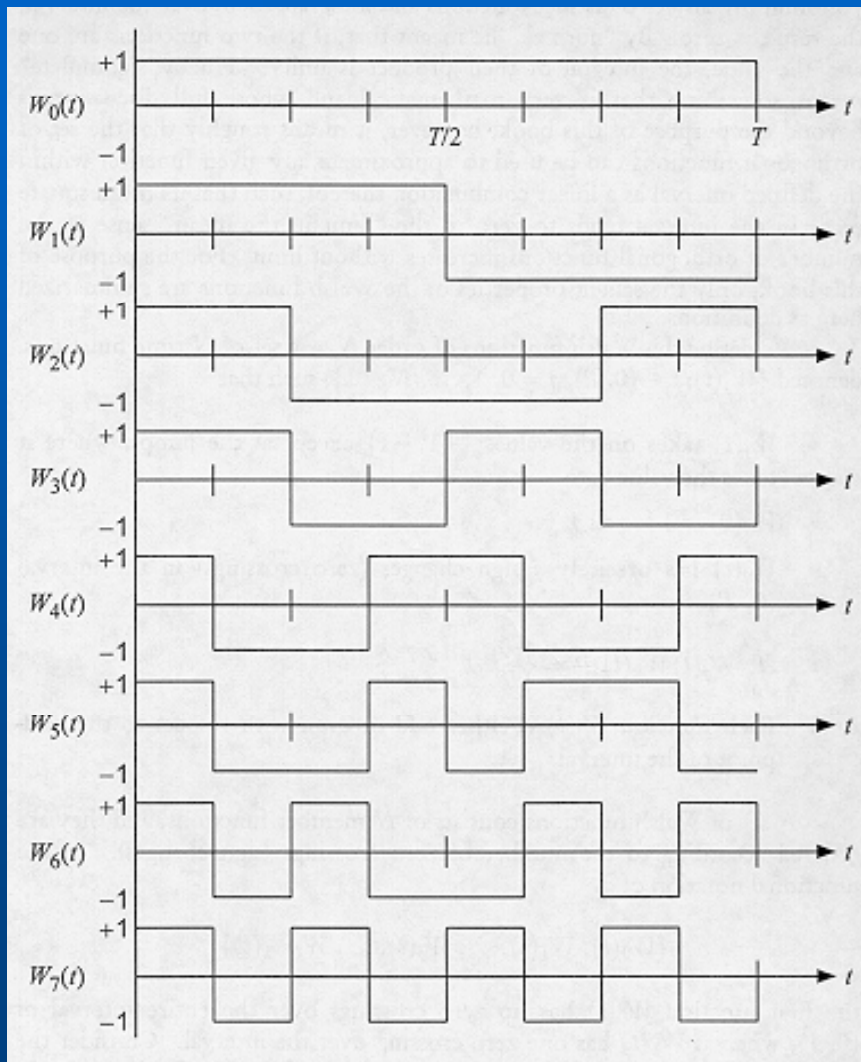

The Walsh Functions of order 8

Walsh Functions (contd.)

Index integer j	Index sequence	Walsh sequences of order $8 = 2^3$
0	000	$W_0 = 00000000$
1	001	$W_1 = 00001111$
2	010	$W_2 = 00111100$
3	011	$W_3 = 00110011$
4	100	$W_4 = 01100110$
5	101	$W_5 = 01101001$
6	110	$W_6 = 01011010$
7	111	$W_7 = 01010101$

+1 → "0"

-1 → "1"

The Walsh Sequence of Order 8

Walsh Functions (contd.)

- A set of Walsh functions of order $N = 2^K$ possess symmetry properties (even or odd) about K axes at $T/2, T/2^2, \dots, T/2^K$

- Consider the 13th Walsh function of order $N = 2^4 = 16$

$$W_{13} = 0101101010100101$$

- The sequence has odd symmetry about $T/2^4 = T/16$
- The sequence has odd symmetry about $T/8$
- The sequence has even symmetry about $T/4$
- The sequence has odd symmetry about $T/2$

Walsh Functions (contd.)

- The above symmetry properties can be generalized
- For e.g. 13 in binary notation can be written as:
 $(1101) = (j_1 j_2 j_3 j_4)$
 - $j_1 = 1 \Rightarrow$ symmetry is odd at axis $T/16$
 - $j_2 = 1 \Rightarrow$ symmetry is odd at axis $T/8$
 - $j_3 = 0 \Rightarrow$ symmetry is even at axis $T/4$
 - $j_4 = 1 \Rightarrow$ symmetry is odd at axis $T/2$
- The sequence may now be written down, starting with 0, according to the above symmetry properties as :

0101101010100101

Walsh Functions on the Forward Link

- IS-95 forward link uses orthogonal multiplexing of the pilot, sync, paging and traffic channels by exploiting the orthogonality of the set of Walsh functions of order 64.

Walsh Functions on the Forward Link (contd.)

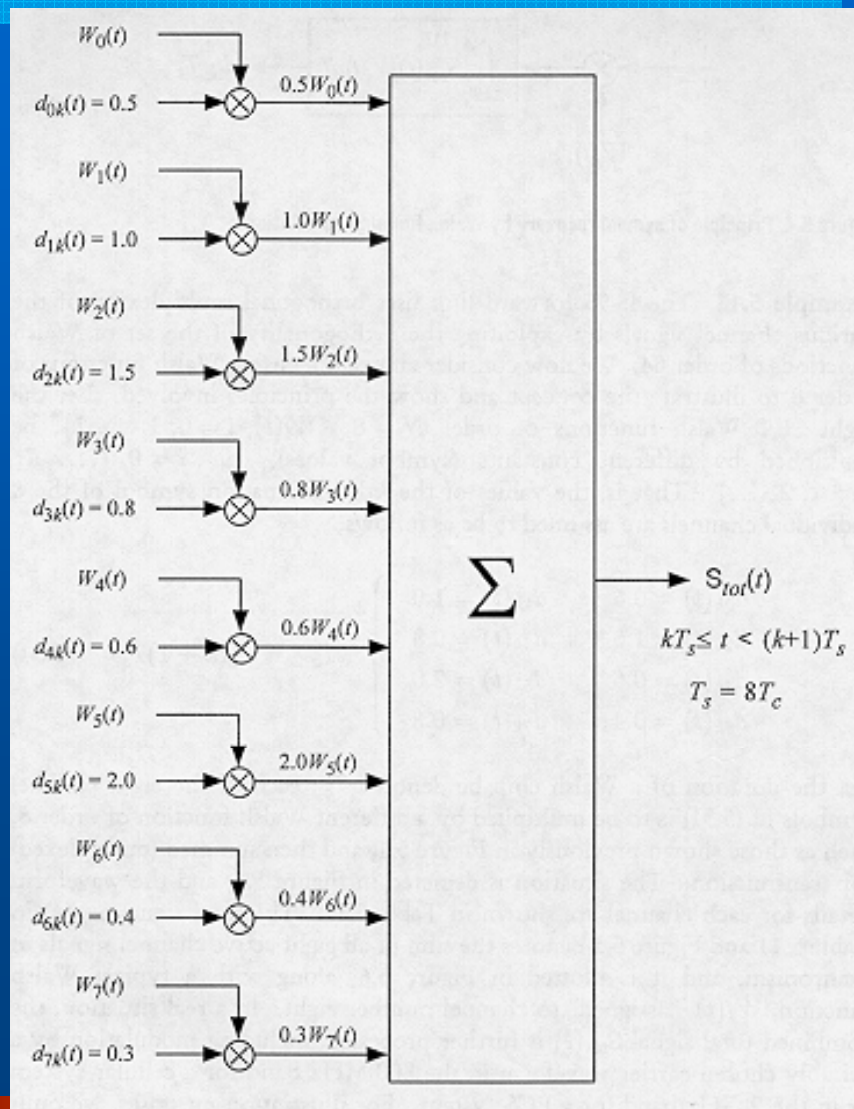

Example of Walsh Function
orthogonal multiplexing, $N=8$

Walsh Functions on the Forward Link (contd...)

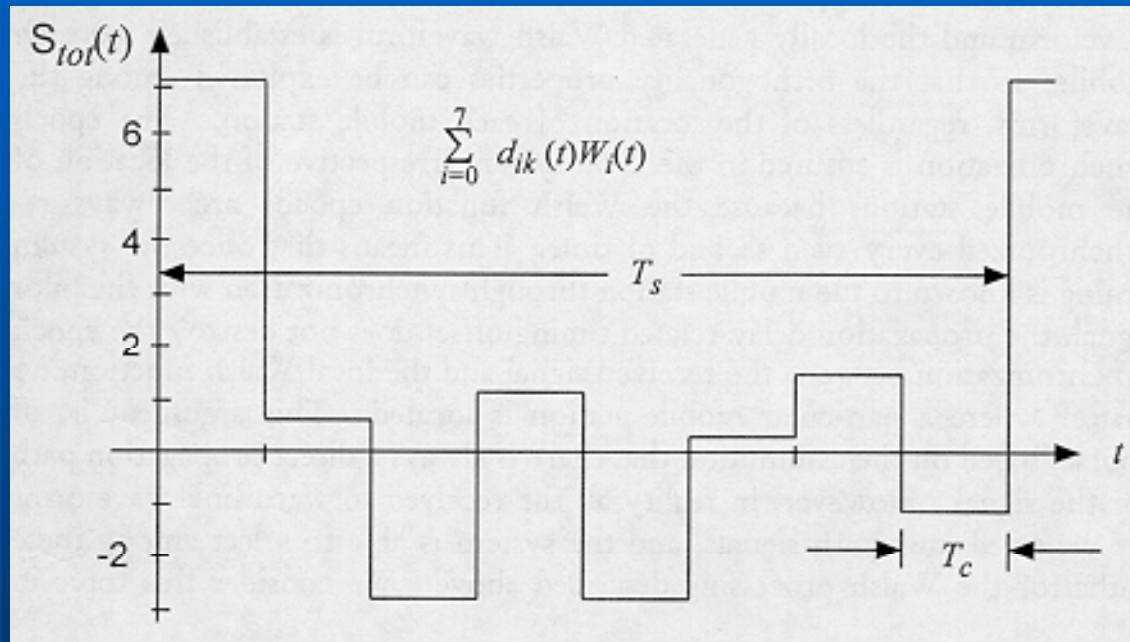

Total multiplexed signal for the N=8

Walsh Functions on the Forward Link (contd...)

	$t = 0$	T_c	$2T_c$	$3T_c$	$4T_c$	$5T_c$	$6T_c$	$7T_c$	Sum/8
$\times W_0(t)$	7.1	0.5	-2.7	1.1	-2.7	0.3	1.5	-1.1	$4.0/8 = 0.5$
$\times W_1(t)$	7.1	0.5	-2.7	1.1	2.7	-0.3	-1.5	1.1	$8.0/8 = 1.0$
$\times W_2(t)$	7.1	0.5	2.7	-1.1	2.7	-0.3	1.5	-1.1	$12.0/8 = 1.5$
$\times W_3(t)$	7.1	0.5	2.7	-1.1	-2.7	0.3	-1.5	1.1	$6.4/8 = 0.8$
$\times W_4(t)$	7.1	-0.5	2.7	1.1	-2.7	-0.3	-1.5	-1.1	$4.8/8 = 0.6$
$\times W_5(t)$	7.1	-0.5	2.7	1.1	2.7	0.3	1.5	1.1	$16.0/8 = 2.0$
$\times W_6(t)$	7.1	-0.5	-2.7	-1.1	2.7	0.3	-1.5	-1.1	$3.2/8 = 0.4$
$\times W_7(t)$	7.1	-0.5	-2.7	-1.1	-2.7	-0.3	1.5	1.1	$2.4/8 = 0.3$

Multiplying $S_{\text{tot}}(t)$ by different Walsh functions for channel information recovery

Walsh Functions on the Forward Link (contd...)

- It is essential that there is perfect synchronization at the receiver, for the orthogonal multiplexing system to work.
- Hence in IS-95 they are resynchronized at every even second of time.

IS-95 CDMA

- Direct Sequence Spread Spectrum Signaling on Reverse and Forward Links
- Each channel occupies 1.25 MHz



- Fixed chip rate 1.2288 Mcps

Spreading Codes in IS-95

- Orthogonal Walsh Codes
 - To separate channels from one another on forward link
 - Used for 64-ary orthogonal modulation on reverse link.
- PN Codes
 - Decimated version of long PN codes for scrambling on forward link
 - Long PN codes to identify users on reverse link
 - Short PN codes have different code phases for different base stations

Forward Link Modulation

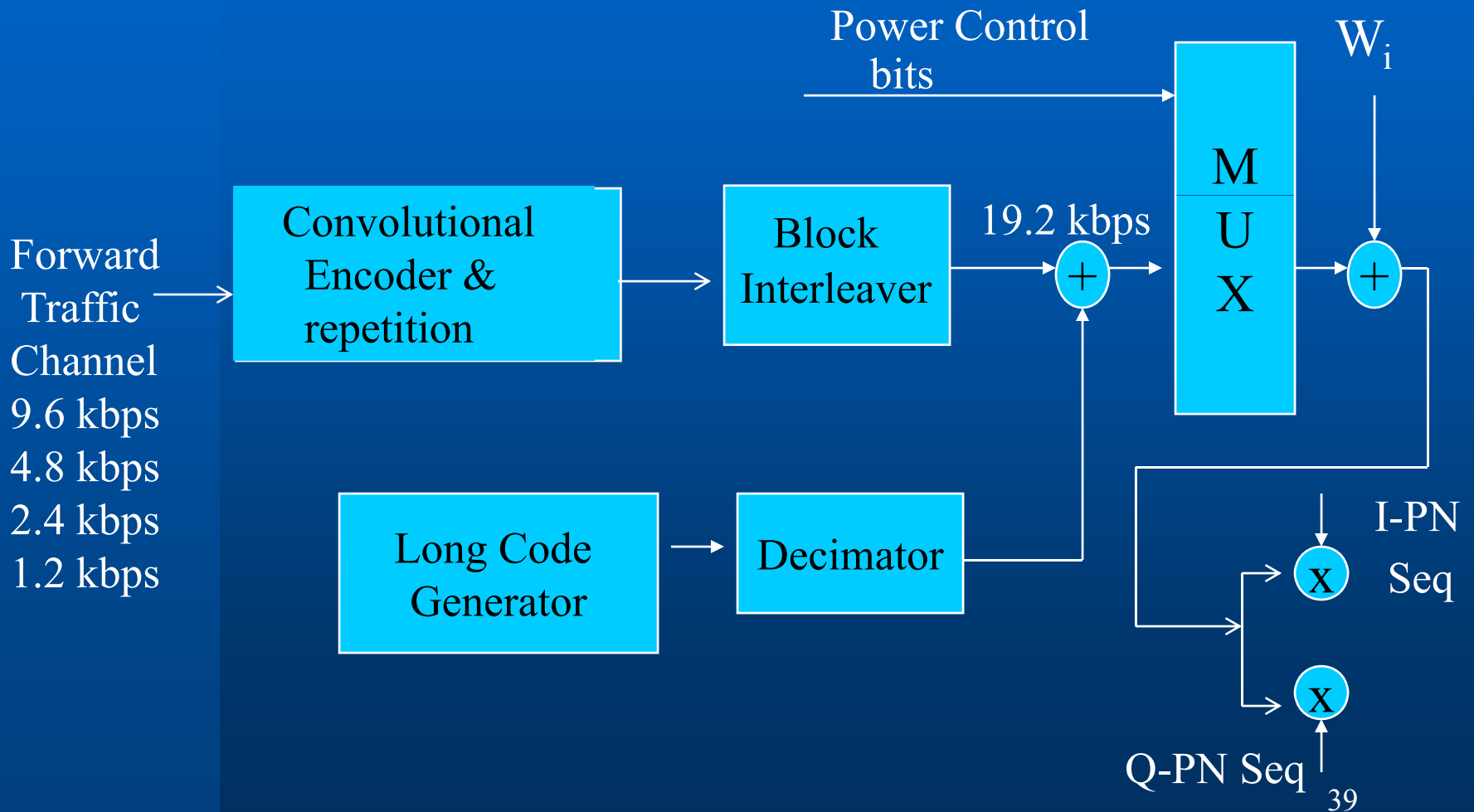

Forward Link Modulation (contd...)

Pilot channel

all 0s (no data)

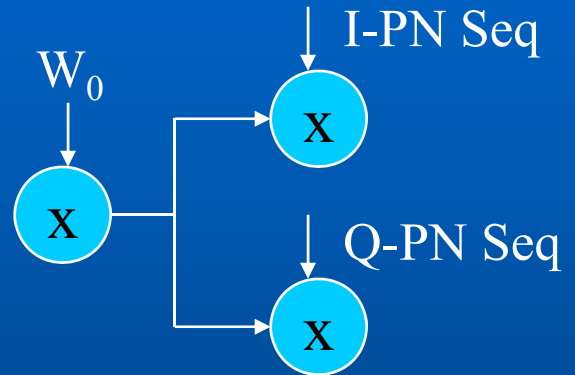

Sync channel

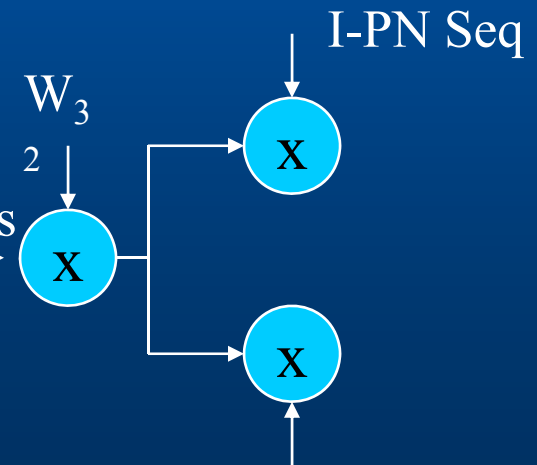
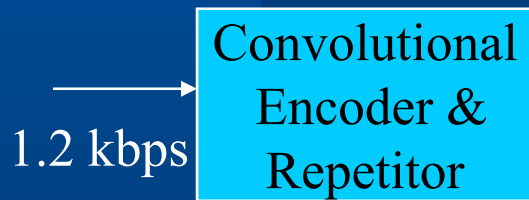

Q-PN Seq ⁴⁰

Forward Link Modulation (contd...)

Paging Channel

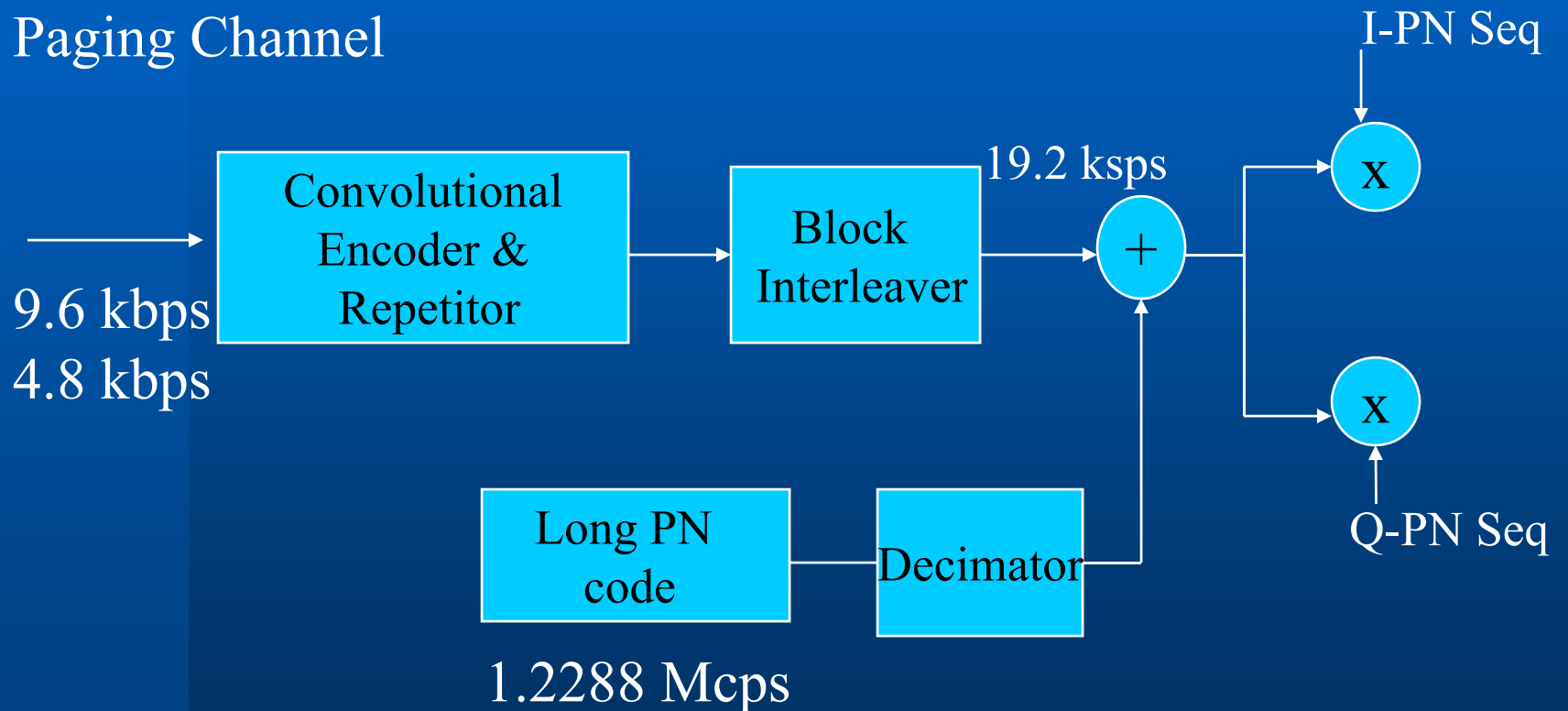

Reverse Link Modulation

- The signal is spread by the short PN code modulation (since it is clocked at the same rate)
- Zero offset code phases of the short PN code are used for all mobiles
- The long code PN sequence has a user distinct phase offset.

Reverse Link Modulation

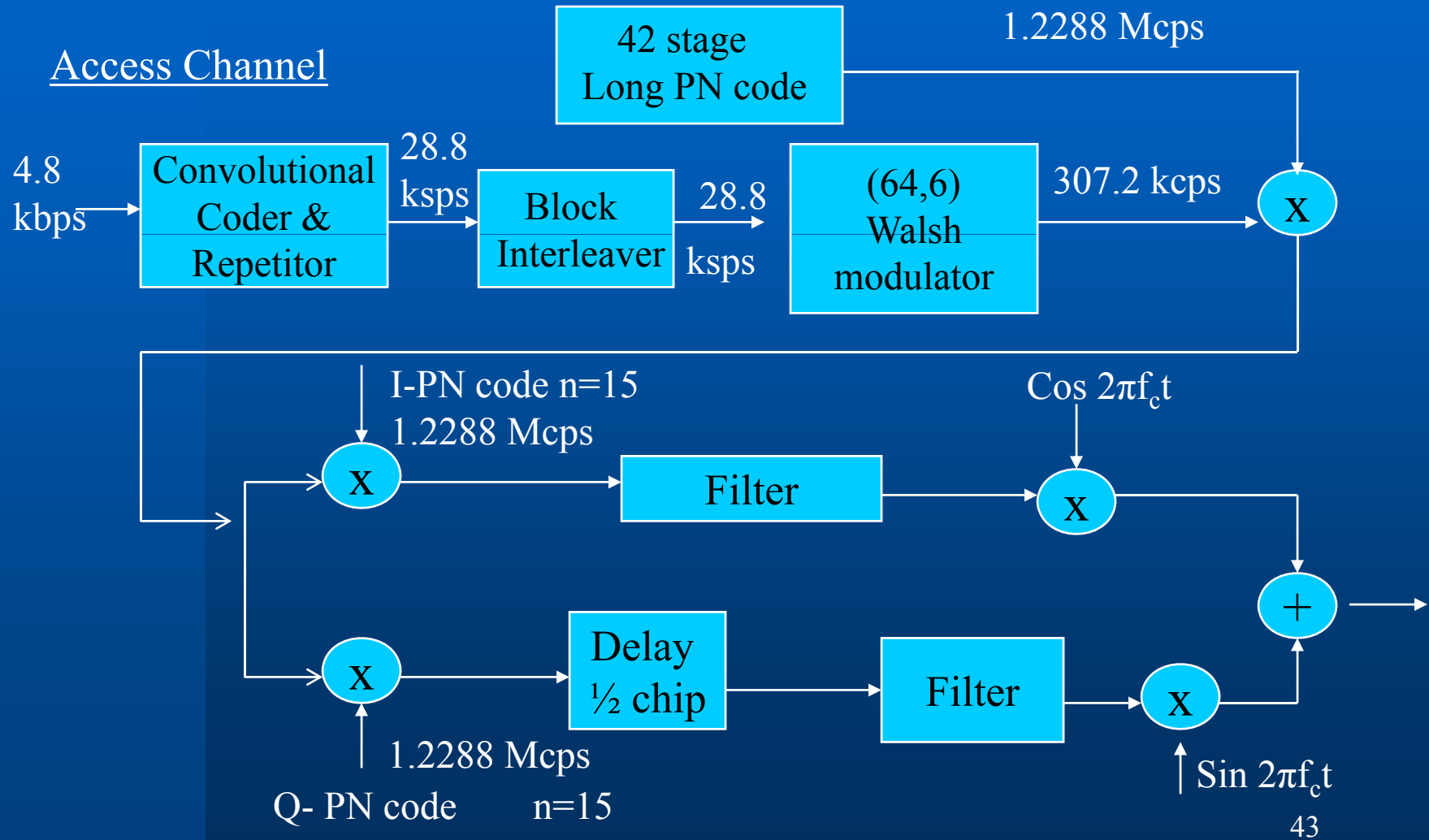

Traffic Channel

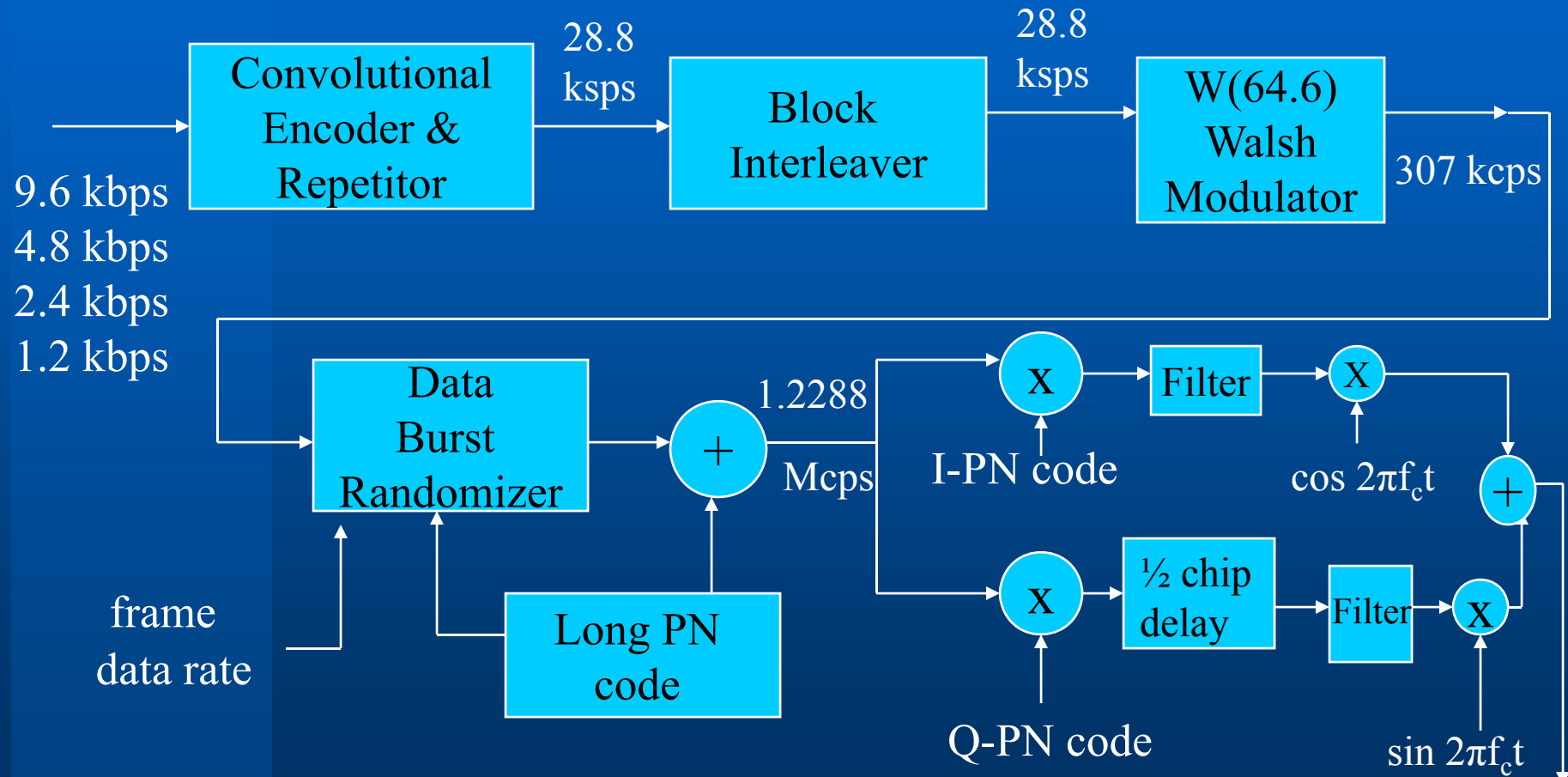

Power Control in CDMA

- CDMA goal is to maximize the number of simultaneous users
- Capacity is maximized by maintaining the signal to interference ratio at the minimum acceptable
- Power transmitted by mobile station must be therefore controlled
 - Transmit power enough to achieve target BER: no less no more

Two factors important for power control

- Propagation loss

- due to propagation loss, power variations up to 80 dB
- a high dynamic range of power control required

- Channel Fading

- average rate of fade is one fade per second per mile hour of mobile speed
- power attenuated by more than 30 dB
- power control must track the fade

Power Control on Forward Link and Reverse Link

- On Forward Link
 - to send just enough power to reach users at the cell edge
- On Reverse Link
 - to overcome the 'near-far' problem in DS-CDMA

Types of Power Control

- Open Loop Power Control (on FL)
 - Channel state on the FL estimated by the mobile
 - measuring the signal strength of the pilot channel
 - RL transmit power made inversely proportional to FL power measured
 - Mobile Power = Constant – Received power
(dBm) (dBm) (dBm)
 - Works well if FL and RL are highly correlated
 - slowly varying distance and propagation losses
 - not true for fast Rayleigh Fading.

Closed Loop Power Control (on RL)

- Measurement of signal strength on FL as a rough estimate
- Base station measures the received power on RL
- Measured signal strength compared with the target E_b/N_0 (power control threshold)
- Power control command is generated
 - asking mobile to increase/decrease
- Must be done at fast enough a rate (approx 10 times the max Doppler spread) to track multi-path fading

Outer Loop Power Control

- Frame error rate (FER) is measured
- Power control threshold is adjusted at the base station

Power Control in IS-95A

- At 900 MHz and 120 km/hr mobile speed Doppler shift = 100Hz
- In IS 95-A closed loop power control is operated at 800 Hz update rate
- Power control bits are inserted ('punctured') into the interleaved and encoded traffic data stream
- Power control step size is +/- 1 dB
- Power control bit errors do not affect performance much

Diversity Techniques in CDMA

Rationale for Diversity:-

if 'p' is the probability that a given path in a multi-path environment is below a detection threshold, then the probability is 'p^L' that all 'L' paths in an L-path multi-path situation are below the threshold

Diversity Techniques

- Frequency Diversity
 - transmission of signal on two frequencies spaced further apart than the coherence bandwidth
 - inherent in spread spectrum system if the chip rate is greater than the coherence bandwidth
- Time Diversity
 - transmission of data at different times
 - repeating the data 'n' times
 - interleaving and error correcting codes used in IS-95
- Space Diversity
 - Multi-path tracking (Path Diversity)
 - Transmission space diversity
 - Signal can be emitted from multiple antennas at a single cell site

Diversity Combining

- Selection Diversity (SD)
- Equal Gain Diversity (EGC)
- Maximal Ratio Combining (MRC)
- MRC is an optimal form of diversity
- RAKE receiver in IS-95 is a form of MRC

Selection Diversity Combining

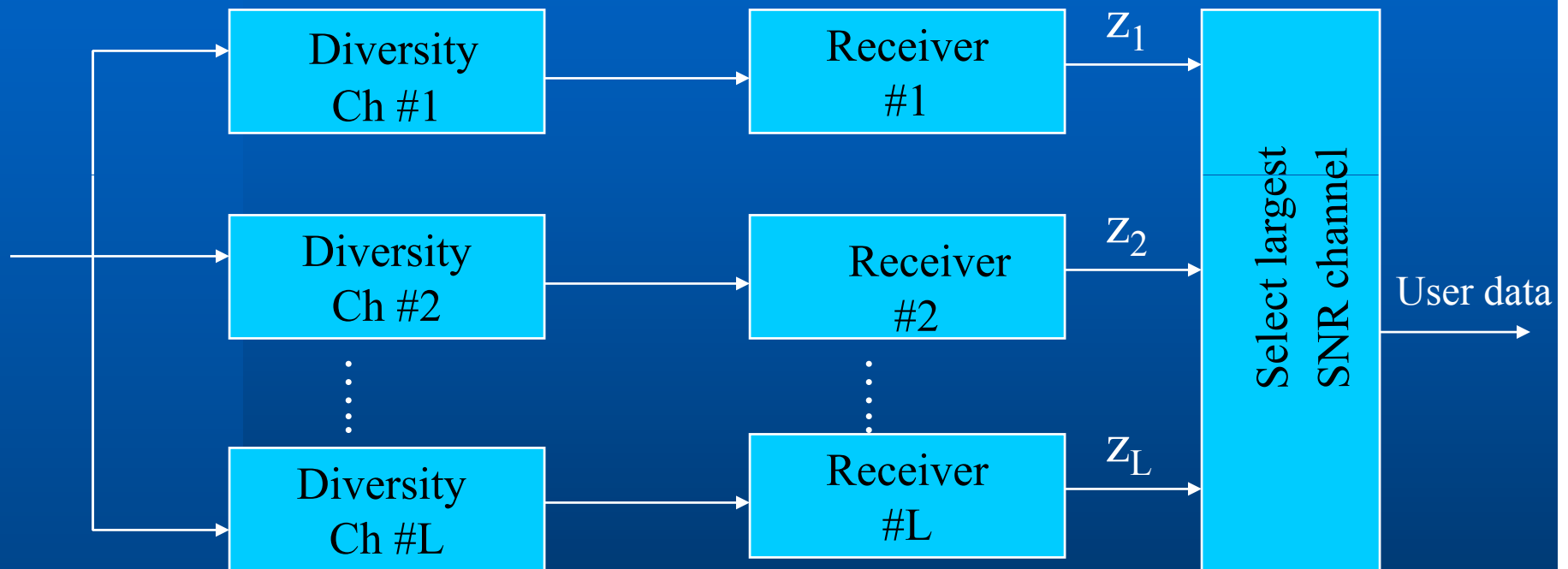

- Channel with the highest SNR is chosen
- $(L-1)$ channel outputs are ignored

Equal Gain Combining (EGC)

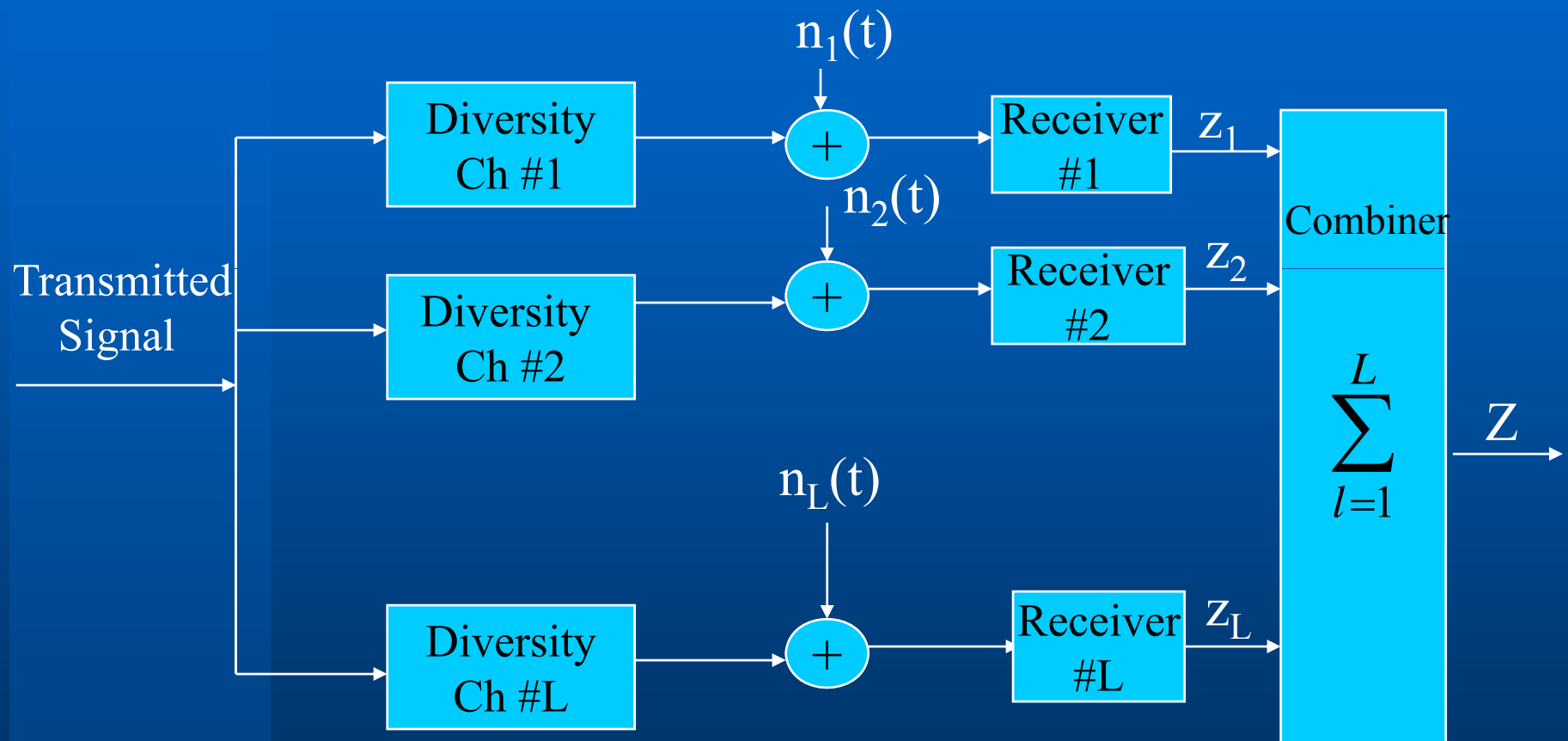

- Symbol decision statistics are combined with equal gains to obtain overall decision statistics.

Maximal Ratio Combining(MRC)

- Similar to EGC – decision statistics are summed or combined
- In EGC – each channel is multiplied by equal gain
- In MRC – each channel is multiplied by gain proportional to the square root of SNR of the channel

$$g_i \propto \sqrt{SNR}_i$$

- This gives optimal combining

$$\text{Output SNR} = \sum_{i=1}^L (SNR)_i$$

- Requires knowledge of SNR of each channel as well as phase of the diversity signal

MRC

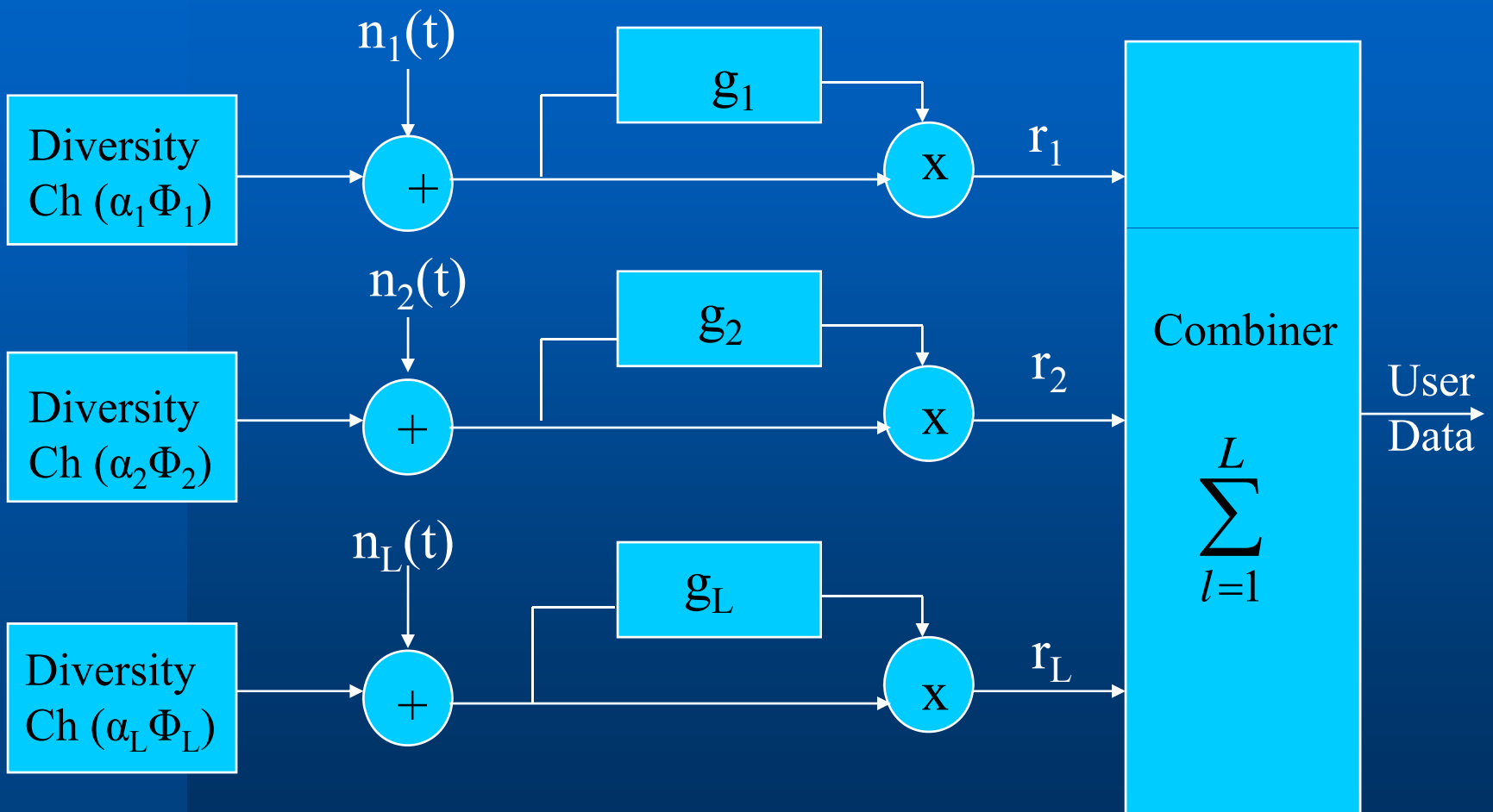

RAKE Receiver Concept

- Multi-path diversity channels
 - Problem
 - to isolate various multi-path signals
 - How to do this ?
 - If the maximal delay spread (due to multi-path) is T_m seconds and if the chip rate $\frac{1}{T_c} = W \gg \frac{1}{T_m}$
- then individual multi-path signal components can be isolated
- Amplitudes and phases of the multi-path components are found by correlating the received waveform with delayed versions of the signal
 - Multi-path with delays less than $1/T_c$ can't be resolved

RAKE Receiver Concept

$$m(t) = C(t) \cos(w_0 t)$$

$c(t)$ is a PN Sequence

$$= E\{C(t) \cos(w_0 t) C(t + \tau) \cos(w_0 t + \tau)\}$$

$$R_c(\tau) = E\{C(t) C(t + \tau)\}$$

$$= E\{c(t) c(t + \tau)\} E\{\cos w_0 t \cos(w_0 t + \tau)\}$$

$$= R_c(\tau) \frac{1}{2} \cos(w_0 \tau)$$

$$R_c(\tau) \approx R_c(0) \left[1 - \frac{|\tau|}{T_c}\right] \quad |\tau| < T_c$$

$$\frac{1}{T_c} = w$$

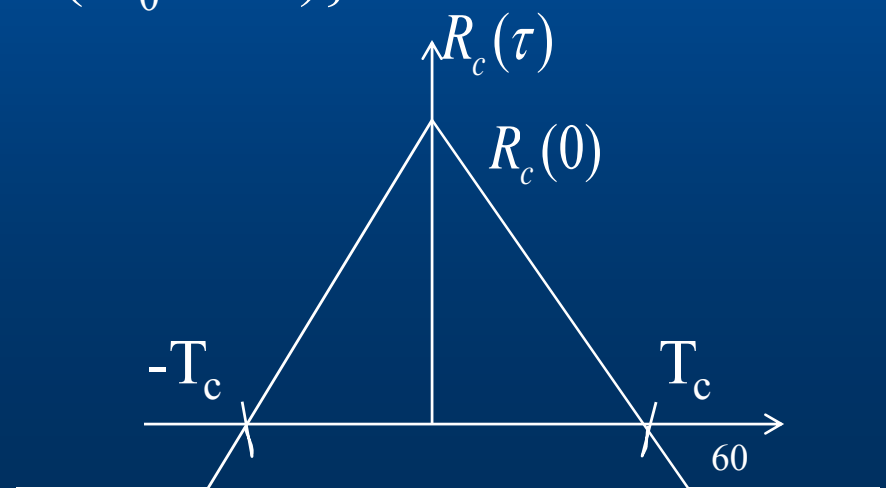

Rake Receiver in IS-95

- Rake Receiver is used in Mobile receiver for combining
 - Multi-path components
 - Signal from different base stations (resolve multi-path signals and different base station signals)
- 3 Parallel Demodulator (RAKE Fingers)
 - For tracking and isolating particular multi-path components (up to 3 different multi-path signals on FL)
- 1 Searcher
 - Searches and estimates signal strength of
 - multi-path pilot signals from same cell site
 - pilot signals from other cell sites
 - Does hypothesis testing and provides coarse timing estimation

Rake Receiver (contd...)

- Search receiver indicates where in time the strongest replicas of the signal can be found

Rake on FL

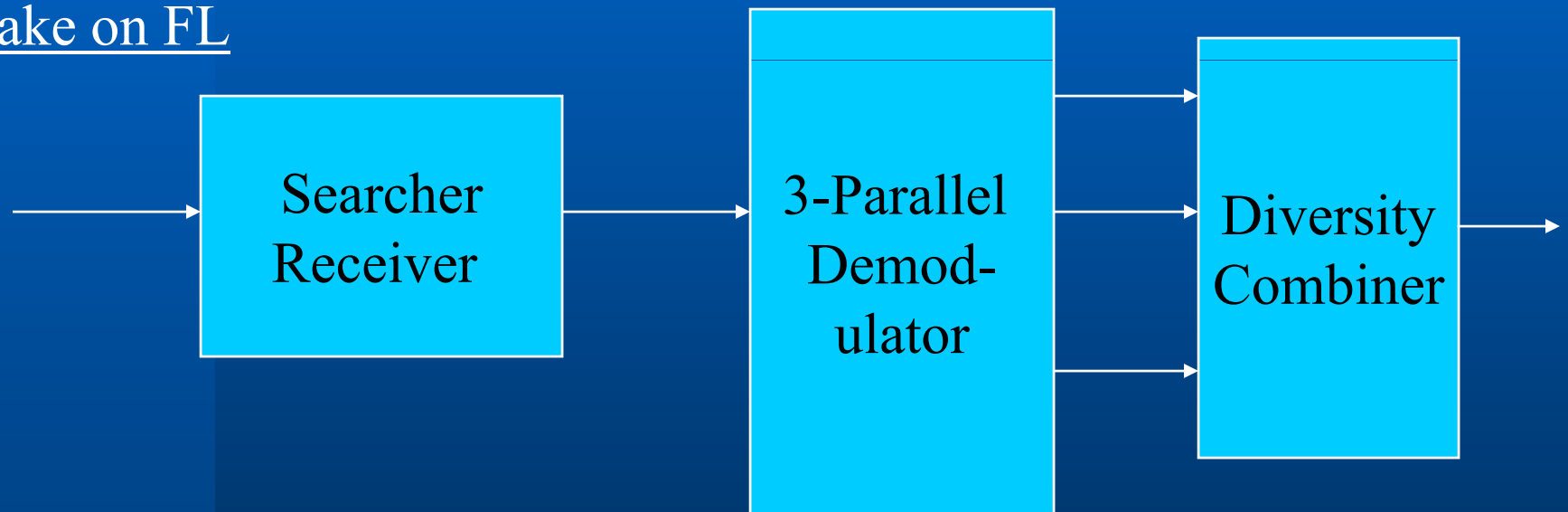

(Mobile Station Rake Receiver)

Handoff in CDMA System

- Soft Handoff
 - Mobile commences Communication with a new BS without interrupting communication with old BS
 - same frequency assignment between old and new BS
 - provides different site selection diversity
- Softer Handoff
 - Handoff between sectors in a cell
- CDMA to CDMA hard handoff
 - Mobile transmits between two base stations with different frequency assignment

Soft Handoff- A unique feature of CDMA Mobile

Advantages

- Contact with new base station is made before the call is switched
- Diversity combining is used between multiple cell sites
 - additional resistance to fading
- If the new cell is loaded to capacity, handoff can still be performed for a small increase in BER
- Neither the mobile nor the base station is required to change frequency

Soft Handoff Architecture

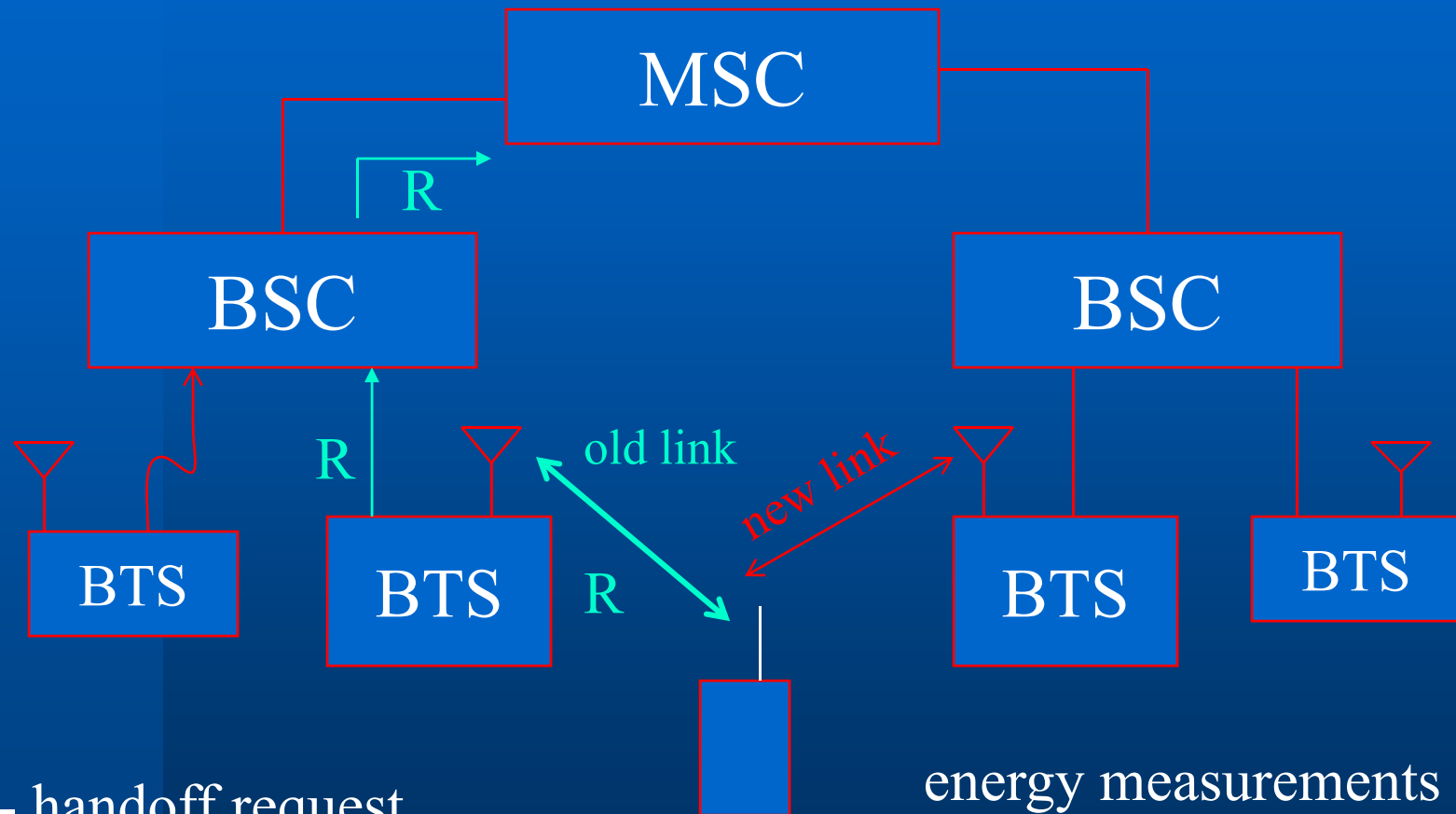

R- handoff request
sent to the old cell

energy measurements
are made at the mobile

Rate Receiver on Reverse Link

- Base station receiver uses two antennas for space diversity reception
- 4 – parallel demodulators
- Since no pilot signal is present, non coherent maximal ratio combining

Rate Receiver on RL (contd...)

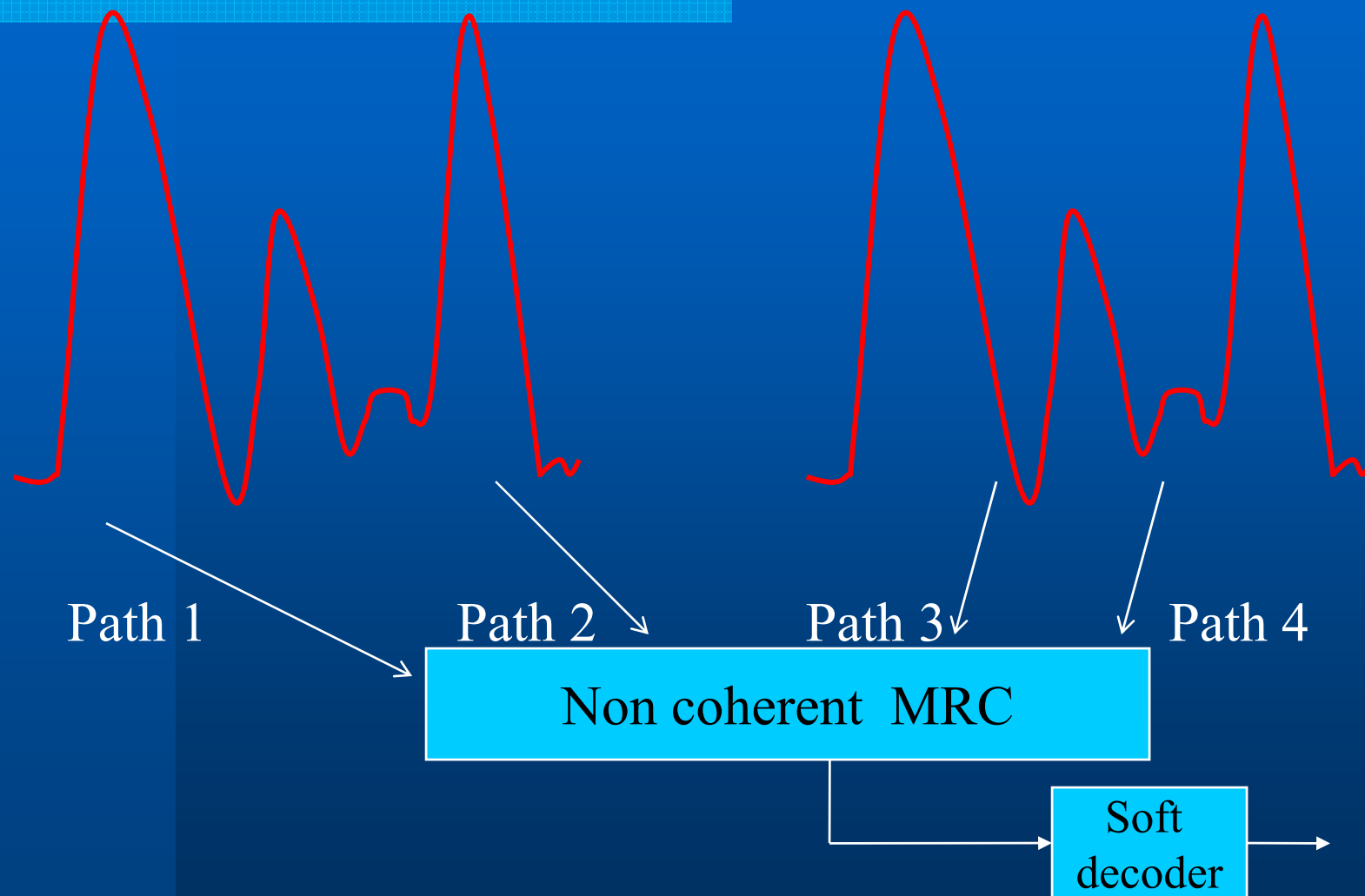

Rake Receiver on Forward Link

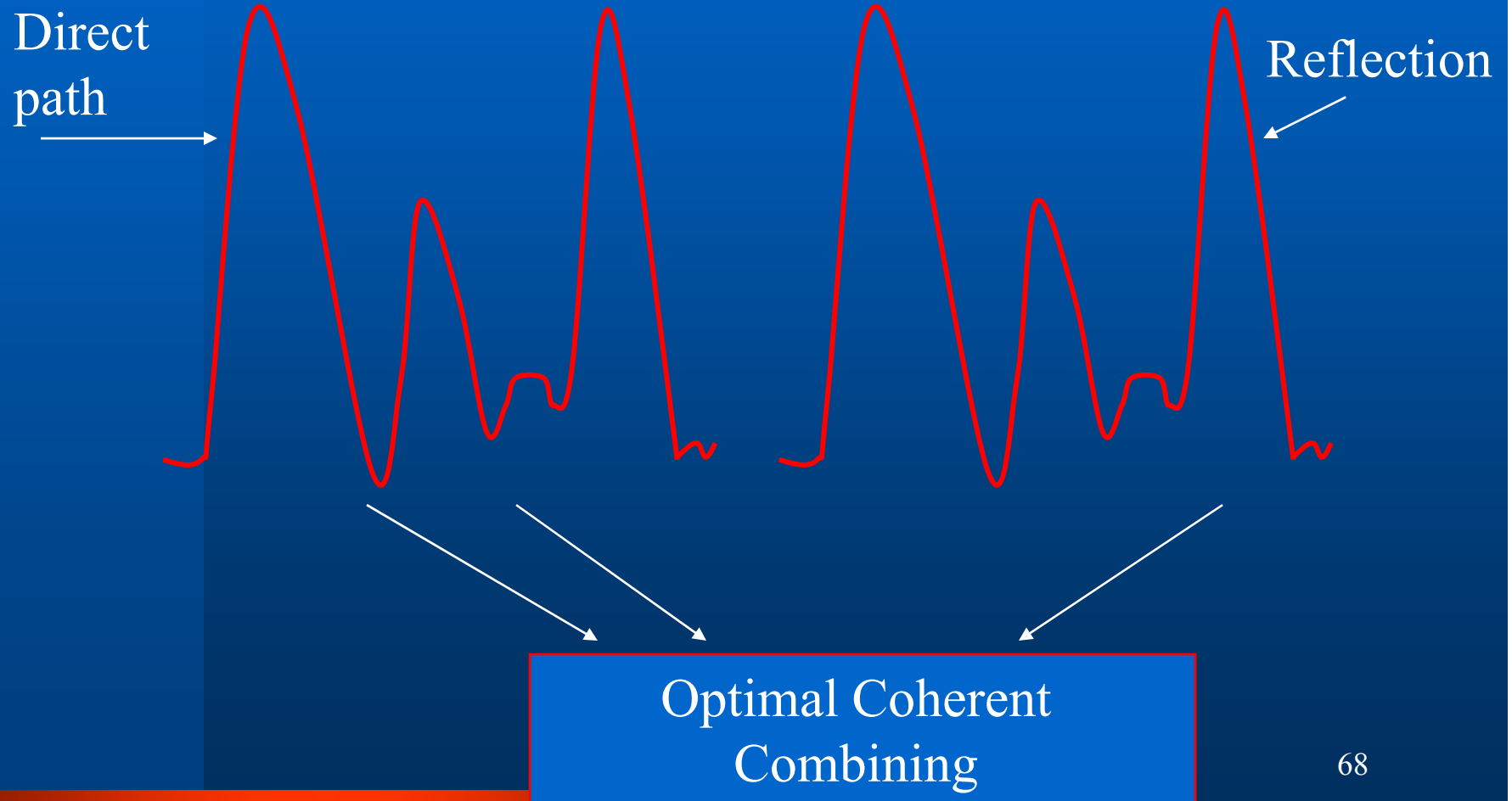

Base station Diversity on Reverse Link during soft handoff

